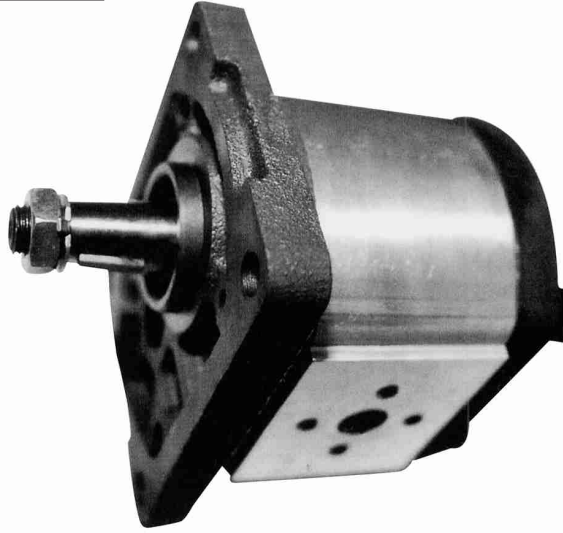
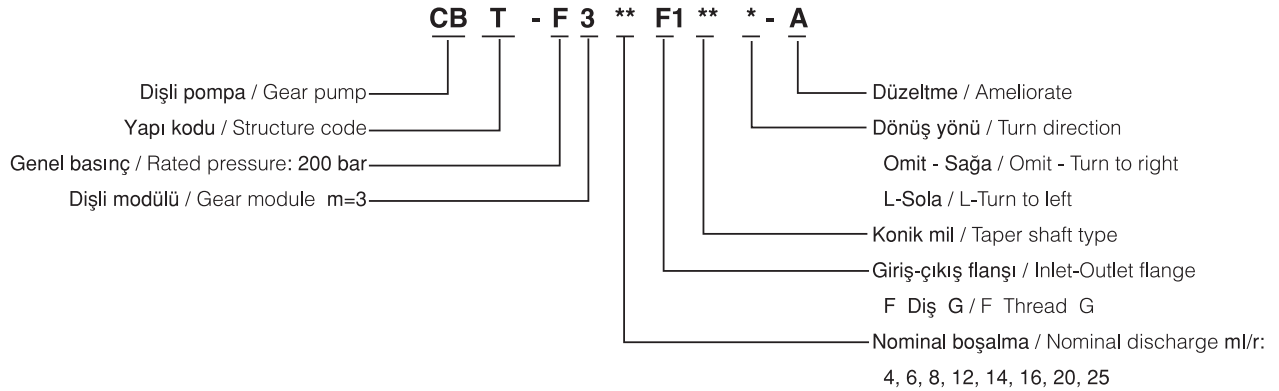

**CBT-F3-A SERİSİ DİŞLİ POMPA / CBD1 - F2 - CC SERIES GEAR PUMP****UYGULAMA VE ÖZELLİKLER / APPLICATION AND FEATURES**

CBT - F3 - A serisi dişli pompa hidrolik sistemlerin dinamik elemanıdır. Pompada 3 tabaka yapı vardır ve otomatik yerini doldurma aksenal temizlik sağlar. DU rulman ve güçlü dökme demir ile donatılmıştır. Basit yapılı, güvenilir iş ve uzun servis süresi karakteristiğine sahiptir. Genel olarak mühendislik hidrolik makinalarında, taşıma makinalarında kullanılır.

CBT - F3 - A series pump is the dynamic component of the hydraulic system. The pump is three sheet type structure and adopts axial clearance automatic compensation device. It is equipped with DU bearing and strength cast iron cover. It has characteristic of simple structure, reliable work and long service life, etc. It is widely used in the hydraulic system of engineering machinery hoist and transport machinery and agriculture machinery.

**MODEL KODU / MODEL CODE****ÖZELLİKLER / SPECIFICATION**

Model	Disp. (m <sup>3</sup> /r)	Basınç(Bar) Pressure(Bar)		Hız / Devir Speed (r/min)			Kullanılan yağ Working oil	Filtre hassasiyeti Filter precision (µm)	Yağ sıcaklığı Oil temperature C°	Hacim verimi Volumetric efficiency (%)	Giriş gücü Input power (kw)	Ağırlık Weight (Kg)
		Rated	Max.	Rated	Max.	Min						
CBT-F304	4	200 bar	250 bar	2000	3000	600	L-HM46 GB/T 7631.2-87	≤ 25	-20 ~ 80	≥ 93	3.2	3.3
CBT-F306	6										4.8	3.4
CBT-F308	8										6.4	3.5
CBT-F310	10										8.0	3.6
CBT-F312	12										9.6	3.7
CBT-F314	14										11.2	3.8
CBT-F316	16										12.8	3.9
CBT-F320	20										16.1	4.0
CBT-F325	25										20.1	4.0

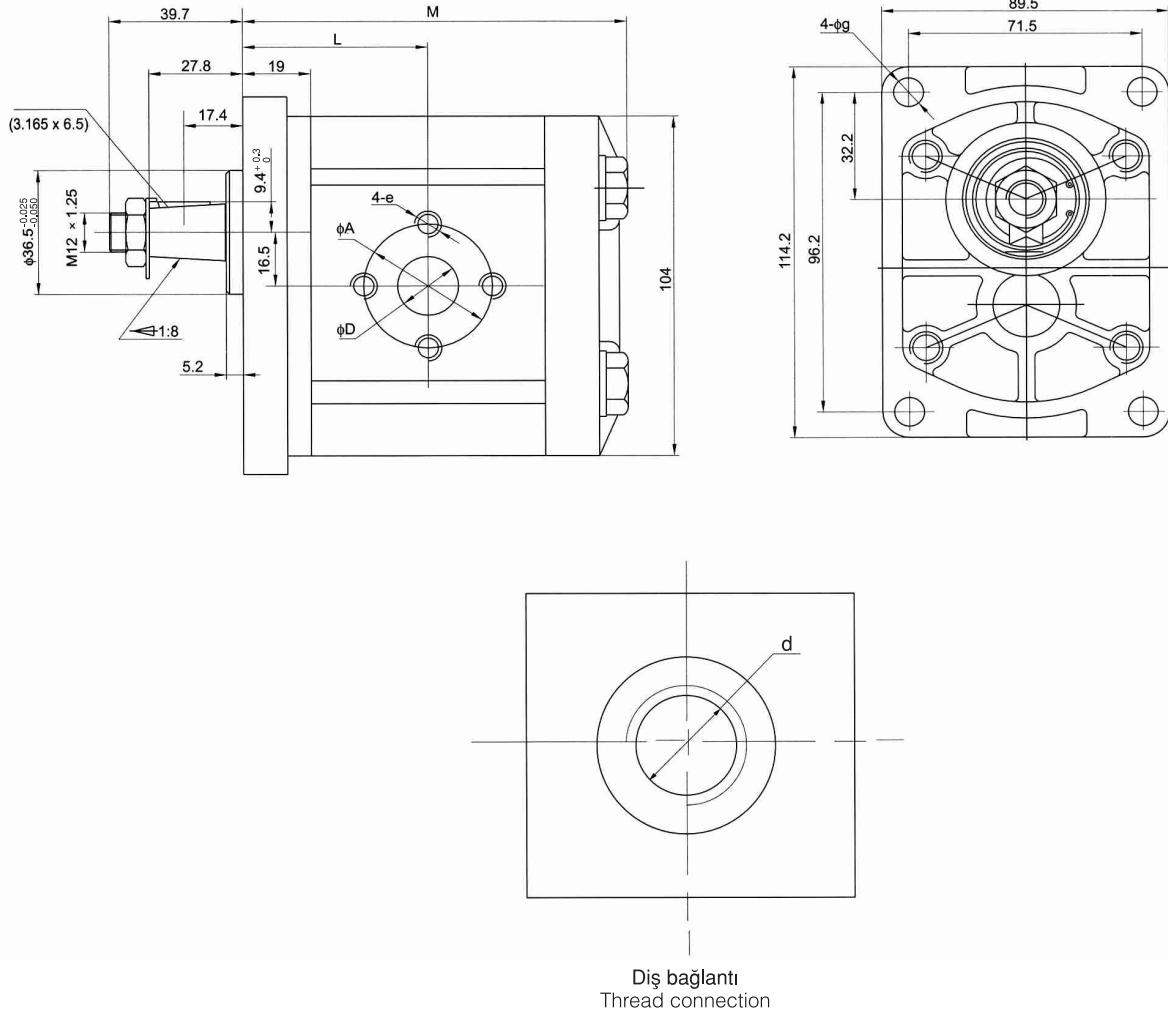
**CBT-F3-A SERİSİ DİŞLİ POMPA / CBD1 - F2 - CC SERIES GEAR PUMP****DIŞ ÖLÇÜLER / EXTERNAL DIMENSIONS****KURULUM ÖLÇÜLERİ / INSTALLATION DIMENSIONS**

Model	M (mm)	L (mm)	Flanş girişi Flanş inlet			Flanş Çıkışı Flanş outlet			Dişli giriş Thread inlet	Dişli çıkışı Thread Outlet
			ØD	ØA	e	ØD	ØA	e	d	
CBT-F304	93	45	13	30	M6	13	30	M6	G 1/2	G 1/2
CBT-F306	95	46								
CBT-F308	98	48								
CBT-F310	101	49	20	40	M8	13	30	M6	G 3/4	
CBT-F312	105	51								
CBT-F314	107	52								
CBT-F316	111	54								
CBT-F320	117	57								
CBT-F325	125	61	22							